

## **LAYER THE QUILT:**

### **Option 1: Spray baste**

Lay the backing on the table with the wrong side facing up and tape it down. Spray with spray baste sparingly.

Lay the wadding on top and spray lightly.

With the right side up lay the top onto the wadding. Smooth out with your hand and press.

### **Option 2: Pinning or tacking**

Lay the backing on the table with the wrong side facing up and tape it down.

Lay the wadding on top.

With the right side up lay the top onto the wadding.

Pin or thread baste all three layers together.

**Note: these instructions are not required if you are having your quilt professionally quilted.**

## **QUILTING:**

Quilt in your preferred manner.

Trim up the quilt top.

## **BINDING:**

Binding is made from 2" wide strips. Join the strips end to end and press the seams open.

Fold the binding in half lengthwise with wrong sides together and press.

Line up the raw edge of the binding with the edge of the quilt right sides together.

Start stitching part way along one side leaving about 6" of binding loose at the beginning.

Mitre each of the corners as you go following the diagrams below.

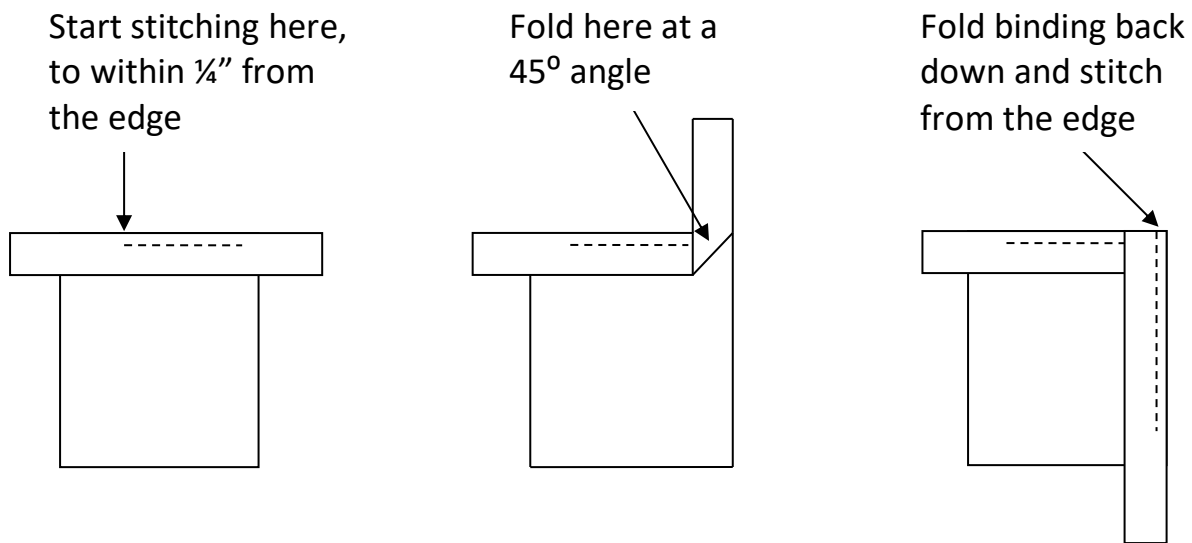

When you get to within approx. 6" of the end remove from the machine.

Measure and join the binding pieces together, continue to sew the remaining binding to the quilt. Once you have finished, fold the binding over to the back and hand sew with a slip stitch.

# APPLIQUÉ METHODS

**Note:** *If you are using cotton thread, then the thread should match the colour of the appliqué pieces and if they don't always match, go a shade darker rather than lighter.*

**HINT:** I use Superior Bottom Line thread for appliqué as it is fine and strong and it blends, eliminating the need to have copious amounts of different coloured threads.

They are now available in Super Bobs which are a bobbin filled with 100yds of thread. They come in a variety of colours and are great when you are a patchworker on the move.

## TRADITIONAL NEEDLE TURN APPLIQUÉ:

- Trace around the template with a Sewline Trio Pencil onto the right side of the fabric.
- Cut out each piece with a scant ¼" seam allowance.
- Place the piece onto the background fabric and glue (I use Sue Daley appliqué glue) or pin into position.
- Using a Milliners needle size 11, a size 15 if you prefer longer, or a 10 if you need a larger eye, turn the seam allowance under little by little and sew with an appliqué stitch.

**Note:** *Sometimes there is an order of placement in which case you need to follow placement in number order.*